

CCG Insight

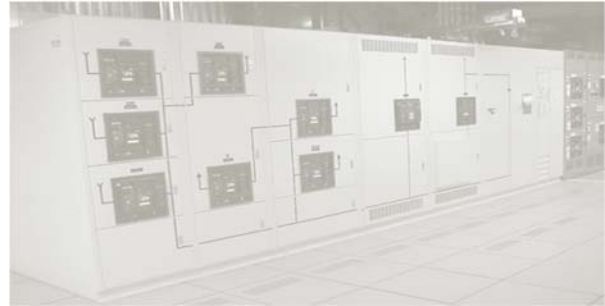

Direct Current Isolated-Parallel UPS Systems

Authored by

Michael J. Mosman, PE
Vice President and Chief Technical Officer

The Isolated-Parallel (“Iso-Parallel” or “IP”) configuration for rotary diesel UPS systems debuted in 2006. The first installations were in wholesale data centers where several customers shared a common facility. Operators of these facilities face the problem of “stranded capacity.” The power demands of one customer might grow beyond the capacity of their allotted UPS while another customer used only a portion of their UPS, and there was no way to let the overloaded customer share the extra capacity of the lightly loaded customer without each being exposed to the faults or maintenance activities of the other.

Iso-Parallel (IP) systems solved this problem. By connecting individual UPS systems to a common bus through fault isolating inductive reactors (“chokes”), power was allowed to flow from a lightly loaded system to an over-demanding customer. The chokes presented little impedance to normal data center power flow, but exhibited high impedance to low power factor fault current flow. All UPS systems end up with identical power output regardless of individual customer demands, because all customer differences are leveled through the Iso-Parallel Bus, and a fault on one system is isolated from all other systems by the natural action of the chokes.

As data center load densities climbed and facilities grew ever larger in size it became economical to elevate the operating voltage of UPS systems from 480 volts to medium voltages, first 4160 volts and later 12,470 volts. Rotary diesel UPS systems (unlike static rectifier/inverter type UPS systems) lend themselves easily to these higher levels. The same applies to Iso-Parallel versions of medium voltage diesel UPS. For over a decade both low voltage and medium voltage Iso-Parallel systems have proven to be extremely resilient and cost effective.

At the same time as data centers were growing in density and size, the industry became more insistent on maximizing the efficiency of data center electrical systems, including power supplies within the computer equipment as well as electrical distribution equipment serving the computer equipment. Typical computer equipment internal power supplies which use AC input power have more power conversion levels (AC to DC and DC to AC) than power supplies with DC input power. Consequently, power supplies with DC input are generally found to be more efficient than AC power supplies.

CCG Insight | Direct Current Isolated-Parallel UPS Systems

Similarly, data center electrical systems that accept electrical utility service at higher voltages and deliver power to computer room distribution equipment with fewer voltage transformations typically exhibit higher efficiency. Medium voltage rotary UPS systems, and in particular IP configured diesel UPS systems, fit well into large scale data centers that strived for overall high electrical systems efficiency.

Currently, and perhaps unfortunately, the data center industry has standardized on AC computer room distribution between 100 volts and 240 volts, and largely prefer low voltage static UPS systems over medium voltage rotary UPS systems. As a result, while medium voltage rotary IP systems with fewer voltage transformations serving computers with DC power rectifiers instead of AC inverters may promise great efficiency gains, widespread acceptance has not occurred. The cost of retrofitting existing data centers to DC power and the reluctance of data center operators deviate from legacy static designs have been large obstacles.

CCG has recently explored an innovative design approach to critical power distribution that combines the robustness of an Iso-Parallel configuration with the power efficiency of a DC delivery system. The goal was to discover a method of critical power delivery that has increased efficiency of both internal computer power supplies and associated external power delivery infrastructure. In addition, the desired application would exhibit the flexibility of an IP system, but make use of familiar static rectifier elements instead of large rotary equipment. Such designs, hereinafter referred to as Direct Current Iso-Parallel (or DCIP) concepts, have the potential to significantly reduce the cost while increasing the efficiency of Iso-Parallel UPS systems used for data center critical power.

Figure 1 below illustrates the basic DCIP concept. It shows “N” modules receiving power from “N” utility sources to serve “N” loads. The power sources need not be the same utility source, and may or may not be backed up with standby power generation. The individual loads need not be the same size, and indeed every load need not be strictly limited to the capacity of the module serving it. The only load limitation is that the total capacity of “N” modules be larger than total of all “N” loads plus the amount of desired redundancy, which should be the capacity of at least one module.

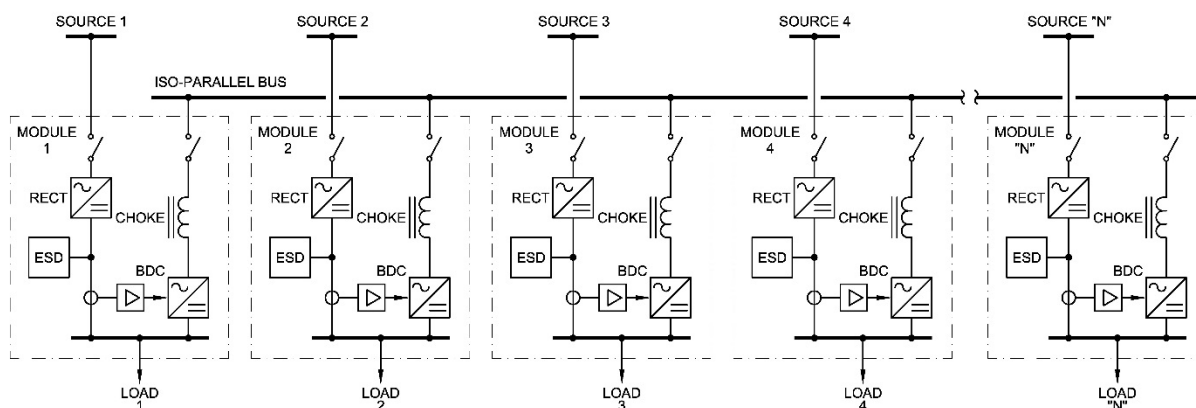

FIG. 1 - TYPICAL DC ISO-PARALLEL DIAGRAM

CCG Insight | Direct Current Isolated-Parallel UPS Systems

Each “power module” consists of five basic components:

1. Three-phase static rectifier (RECT) to convert AC utility power to DC critical power for the module’s dedicated load.
2. Energy storage device (ESD) which is usually chemical batteries, but may also be flywheels or super capacitors, for ride-through power in event of short utility power outages.
3. Single-phase bidirectional power converter (BDC) which facilitates power flow between the DC load bus and an AC Iso-Parallel bus, either into or out of the load bus depending on whether the level of power demand at the load is greater or less than the average power demand of all the modules.
4. Inductive reactor (CHOKER) between the BDC and the IP bus to limit fault current flow among modules.
5. BDC control logic to regulate the BDC power flow frequency on the IP bus side inversely to the power demand on the rectifier and ESD. (The control method is similar to “droop” control in which the frequency drops when load increases, causing the choke to draw power out of the IP bus, or rise when load decreases, causing the choke to push power into the IP bus.)

Besides all the advantages of an IP system, such as distributed redundancy, fault isolation and elimination of stranded capacity, the DCIP concept allows great flexibility in the construction of the IP bus. As mentioned above, it may be constructed as a single-phase circuit since all power into or out of the bus is converted to DC. Furthermore, the IP bus need not be limited to utility frequency and may be operated at significantly higher frequencies thus allowing all magnetics, including the choke, to be much smaller physically. This is a significant enhancement in the economy of Iso-Parallel systems.

CCG Facilities Integration is pleased to announce that Michael Mosman has been granted a US patent for a “Direct Current Iso-Parallel Uninterruptible Power Supply System”.

For more information contact:

CCG Facilities Integration Incorporated

1500 S. Edgewood Street | Baltimore MD 21227

Phone 410-525-0010 | Fax 410-525-1570

www.ccgfacilities.com